

Fabrication

#4 Drilling

This brief gives advice for:

- **Equipment**
- **Procedures**
- **Trouble Shooting**
- **Equipment Suppliers**
- **Additional Technical Information and Assistance**

Equipment

Drills

Any commercially available, power-driven equipment is acceptable. This includes portable drills, drill presses, lathes, automatic multiple-spindle drilling units, CNC routers and machining centers.

Drill Bits

Several manufacturers offer drill bits designed especially for plastics. Drill bits are commonly made of high-speed steel (HSS), cobalt, HSS with carbide tips or solid carbide. Metal-working high-speed steel twist drill bits can be used *with some modification*.

Standard metal-working drill bits are designed to aggressively cut into metal as they are fed into it. If used on acrylic without modification, these bits will chip and cause other damage to the plastic. These drill bits must be reground in order to scrape the plastic instead of sharply cutting into the material and gouging it. There are three points to consider when modifying a standard metal-working twist drill for plastics.

1. Tip angles on standard drill bits are commonly 118°-130°. This point angle must be ground to 60°-90°. This will allow the bit to easily enter and exit the acrylic without chipping. Larger tip angles commonly cause cracking and blow out as the bit exits the sheet. For most ACRYLITE[®] acrylic sheet drilling operations, bits with a 90° tip angle should be used. A bit with a 90° tip angle will generate smaller chips which are easier to evacuate, reducing melting and improving hole quality. Care must be taken at the points of entry and exit. Generally, bits with a 90° tip angle are recommended. Bits with 60° tip angles are also used, especially for holes with diameters of 1/2" and greater.

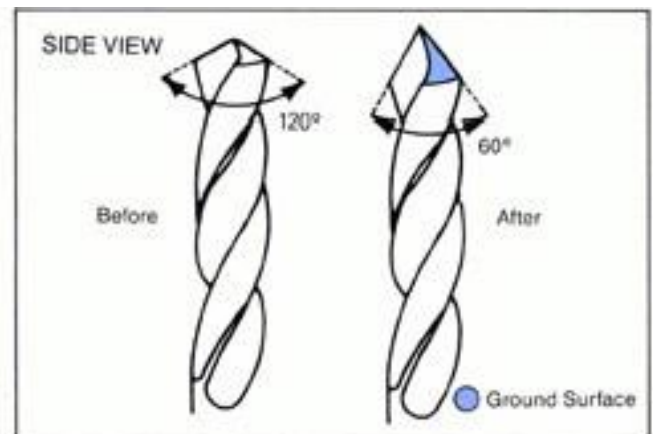

- The cutting edge must be ground "flat" to a 0-4° rake angle. This cutting edge will scrape the acrylic, not gouge it.

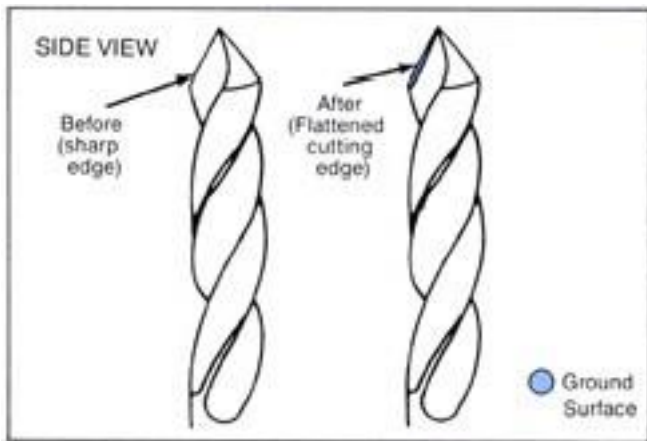

- The surface behind the cutting edge must be ground away to clearance angles of 12-15°. This back relief reduces metal/plastic contact and heat build-up. This modification is standard on most high quality twist drill bits.

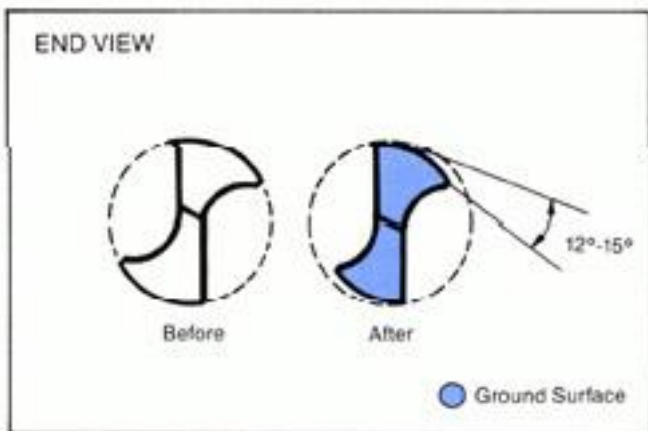

Bit geometry affects the quality of drilled holes since it affects chip size and chip evacuation. Larger diameter bits and bits with smaller tip angles produce larger chips. If hole depth (H) is less than bit diameter (D), large chips are easily ejected. As the depth of the hole increases, i.e. $H > D$, larger chips become more difficult to eject because of the close clearance between the bit and the hole walls. Increasing bit tip angle decreases the size of generated chips, facilitating chip ejection. However, as mentioned above, if the tip angle is too large, larger than 90°, blow out and chipping may be a problem when the bit exits the acrylic.

The helix angle on a bit is the angle between the cutting edge and a vertical line along the center of the bit. Bits with a moderate helix angle aid in chip ejection and are recommended for drilling of plastics. Small helix angles interfere with chip ejection, increasing melting. Helix angles, which are too large, can cause cracking around the hole edges. Typically a helix angle of 15-30° is recommended.

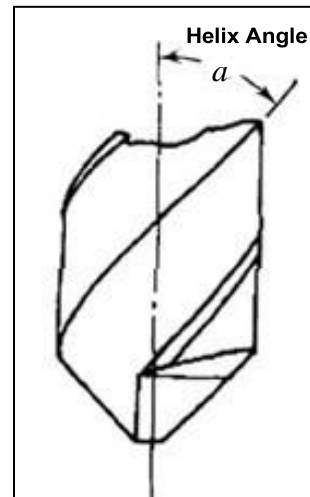

Procedures

Be sure to follow the manufacturers' safety recommendations for equipment and materials used with ACRYLITE FF® acrylic sheet.

When drilling ACRYLITE sheet, heat is generated due to the close clearance between the bit and the hole walls and because of the difficulty of chip ejection. As mentioned above, chip ejection becomes more difficult as the hole gets deeper. Friction between the bit and the material also increases because of acrylic's relatively low thermal conductivity and high thermal expansion coefficient, which cause the material to expand. These factors, if not accounted for, can cause the material to melt and gum, giving less than optimum hole quality. It is therefore essential to reduce generated heat and to remove chips quickly.

The work piece should be held firmly or, preferably, solidly clamped to the worktable. It is best to backup the piece being drilled with acrylic, other thermoplastic sheet or medium density fiberboard (MDF) so the drill bit will continue on into solid material as it penetrates the bottom surface. This will prevent chipping of the bottom surface. Use a slow feed rate when starting the drilling action to allow the bit to enter the material, and also slow the feed rate as the bit exits the bottom surface to prevent chipping.

Suggested Drilling Conditions

Appropriate drilling conditions are a combination of both spindle rotation speed (RPM) and feed rate (IPM). Two parameters are usually employed for determining these. They are:

SFM (surface feet per minute) - the speed at which the cutting edge of the drill bit strikes the material.

IPR (inches per revolution) - the amount of material being removed per revolution of the drill bit, also referred to as chip load.

The SFM and IPR cannot be directly set on manually operated drilling equipment. However, SFM and IPR data can be used to determine proper settings for spindle rotation speed in RPM (revolutions per minute), and feed rate in IPM (inches per minute). If the optimum SFM and IPR are known, then the settings can be determined using the following equations:

$$RPM = \frac{3.82 \times SFM}{D}$$

$$IPM = IPR \times RPM$$

For drilling acrylic the recommended values for SFM and IPR are given in Table 1 below.

Table 1: Recommended values for SFM and IPR

Diameter of bit (in.)	SFM	IPR
1/16	20-160	0.001
1/8	20-160	0.002
1/4	20-160	0.004
3/8	20-160	0.006
1/2	30-90	0.008
3/4	30-90	0.010
≥1	30-90	0.012-0.015

These recommended values can be used with the above equations to determine drilling settings. Alternatively, figures 1, 2, and 3 provided below and on the next page can be used.

Figure 1: Spindle Speed recommendations (RPM) for drilling acrylic (D=0.063"-0.375")

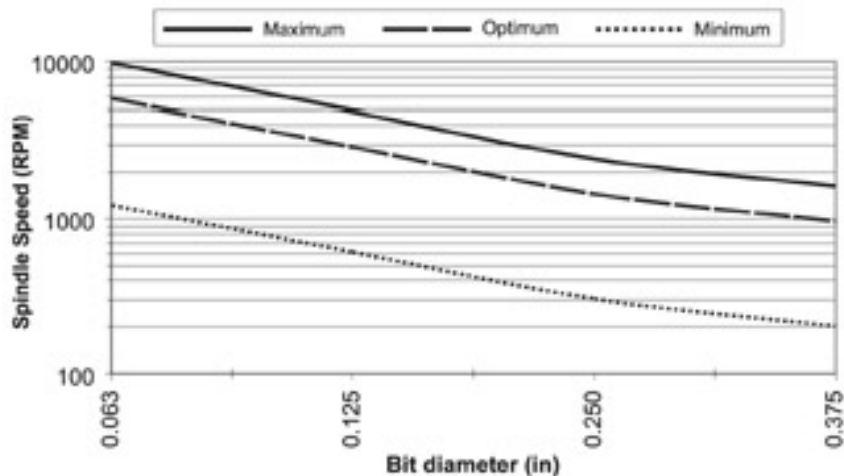

Figure 2: Spindle Speed recommendations (RPM) for drilling acrylic (D=0.380"-1")

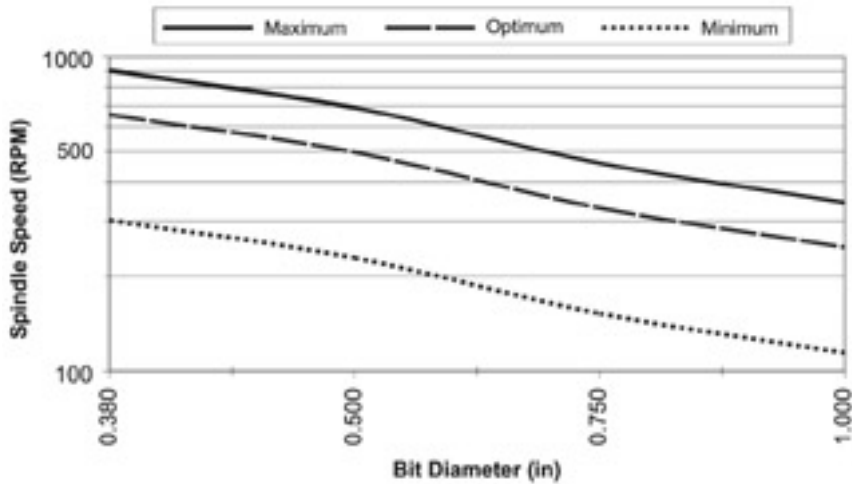
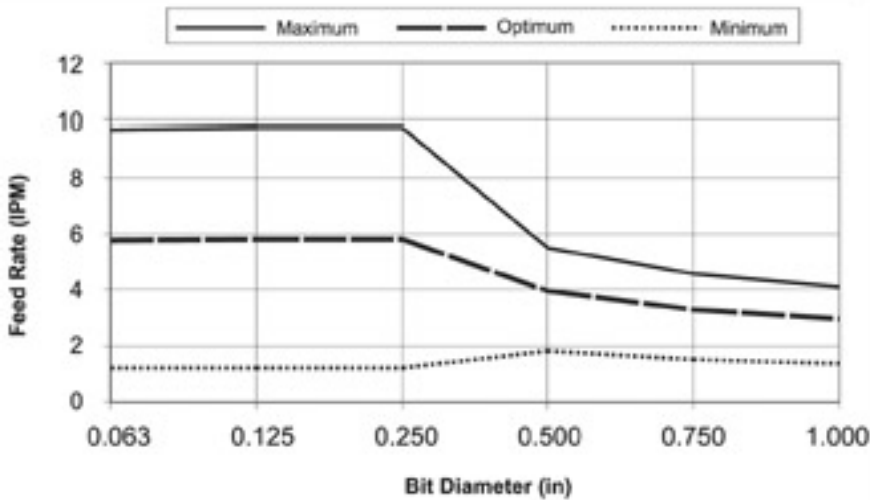

Figure 3: Feed rate (IPM) recommendations for drilling acrylic



As indicated in the graphs and table above, lower SFM's are required for larger drill bits. This is to ensure smooth, vibration-free drilling because large bits will tend to grab the material more. As a result, feed rate must generally be slowed down in order to prevent chipping and consequently spindle speed must be reduced to prevent melting.

For H>D, peck drilling, drilling in increments and removing the bit from the material periodically to clear chips, should be employed.

Manual Drilling

Manual drilling operations should be performed at slower speeds and feed rates than automated or CNC drilling, taking into account the diameter of the bit, material thickness, and ability to cool during drilling. Additionally, peck drilling should be employed in deeper holes to reduce melting.

It is difficult to precisely control feed rate in manual drilling operations. Hole finish can be used as a guide for appropriate feed rates once the correct RPM is established. If the material chips, feed rate is too fast and must be decreased. If the material melts, feed rate is too slow and must be increased.

Shape of Chips

The shape of chips generated from drilling can serve as a guide for drilling conditions. Optimum conditions result in smooth surface holes with smooth, continuous chips. If chips are crumbly and the cut is uneven, the feed rate is too high or RPM is too low. Chips that are molten and holes that show melting indicate that feed rate is too low or RPM is too high.

Coolants

Air or liquid coolants should be used whenever possible. Coolants reduce generated heat, and therefore improve hole quality. In certain hole depths and sizes, coolants are necessary to prevent melting. As a general rule, coolants should be used when the depth of the hole (H) exceeds bit diameter (D) (e.g. for $D=0.250$ ", a coolant should be used for $H>0.250$ "). Coolants should also be used for holes greater than or equal to $1/2$ " in diameter ($D \geq 1/2$ ").

Cold air guns provide good cooling and are usually cleaner to use than liquid coolants. However, liquid coolants provide more cooling, as the liquid can trickle down the hole as the bit goes through the material, resulting in better hole finishes. Water, kerosene, mineral oils and other **compatible** solvents can be used.

Deburring and Countersinking

Holes which may be subject to forces from screws or bolts should be deburred with a countersink. Zero flute countersinks work well for the countersinking and deburring of holes in acrylic sheet. If a countersink is unavailable, use a drill of larger diameter than the hole and deburr the rough edge on the exit side of the hole (side where the drill came through the sheet).

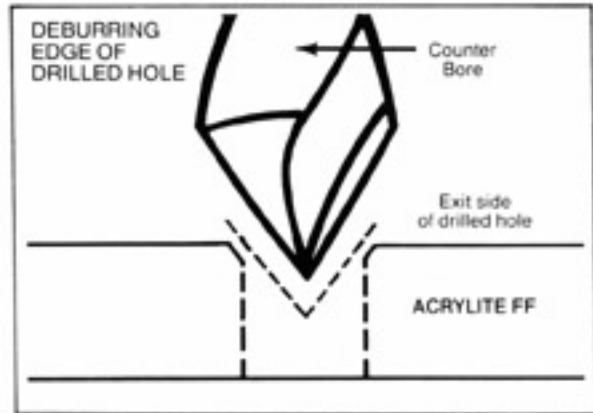

Circuit Board Drilling

Circuit board drilling is a special case where automated machines drill thousands of tiny holes at very high speed. Specially designed bits are required. Feed rate and RPM recommendations are provided in figures 4 and 5.

Figure 4: Spindle speed (RPM) recommendations for acrylic circuit board drilling

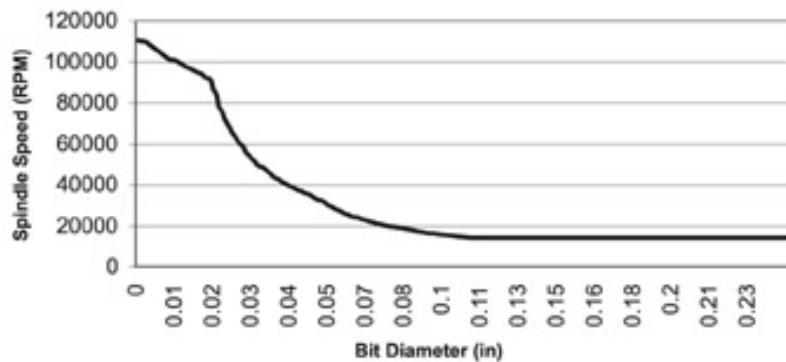
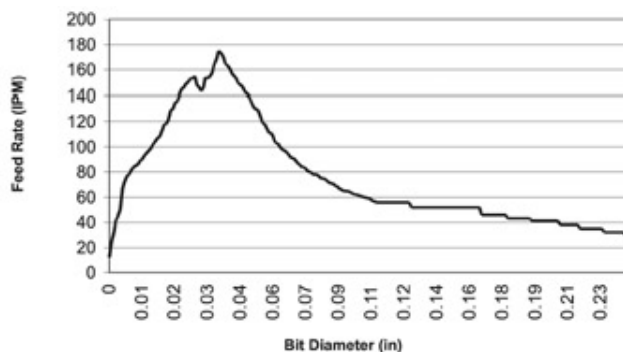

Figure 5: Feed rate (IPM) recommendations for acrylic circuit board drilling



Drilling Large Holes

To drill a hole in ACRYLITE FF sheet greater than 1" (25.4 mm), a circle cutter may be used. The cutter bit must also be modified to accommodate the material properties of acrylic. The tip must scrape the acrylic, not gouge it. For optimum cutting with circle cutters consider the following recommendations:

- The fly cutter and cutting tool itself must be secured properly. Cutting tool must only be extended enough to achieve the desired depth of cut.
- ACRYLITE FF sheet must be adequately supported and clamped to prevent flexing or vibration during the cutting operation. The material should also be placed as close to the fly cutter as possible to reduce the distance the cutter has to travel.
- A spindle speed of between 400-600 rpm is recommended.
- A slow, steady feed rate is very important to achieve a clean, smooth hole. When the hole has been completed and the "blank" has freed itself, turning the drill press off without removing the cutter, is desirable in order to prevent any chipping of the hole during tool exit.

A light misting of water is also recommended to keep the cutter and plastic cool, and also to act as a cutting lubricant.

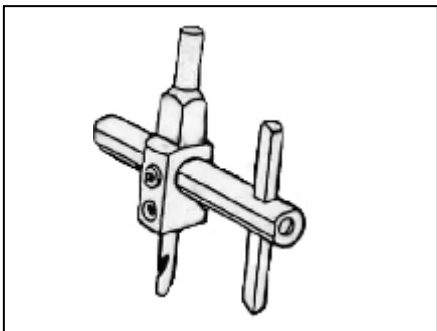

For information on the proper cutter bit specifications contact CYRO Industries, Technical Service at (203)-795-6081.

CAUTION: A circle cutter should only be used in a drill press with the acrylic sheet securely clamped to the machine table. The drill press provides the uniform pressure and constant positioning essential for a safe drilling of quality holes. *Never attempt to use a circle cutter with a hand-held electric drill.*

Drilling - Onsite Installations

The previous sections dealt with controlled production and shop applications. Understanding this information is invaluable for many hole making requirements. Additionally there are times that holes need to be made, such as at a job site, where there is limited control of the exact speeds and feeds that are being used. In these situations, the following bit recommendations may be helpful.

Several drill bit geometries are described below that can be used with success, although most do not leave the inside diameter of the hole with a smooth finish. These bits require the same considerations for support behind the sheet and for cooling as previously reviewed for twist drills bits.

Spade Bit (2" to 1-1/2") - use an advanced design such as the Irwin "SPEEDBOR 2000"® which has spurs on the outer edges to aid in alignment and provide smooth break through when the bit exits the material.

Brad Point Bit (1/8" to 1") - this design is similar to a twist drill with a modified tip similar to a spade bit with spurs. It has an advantage over a spade bit because it has a helical flute design which will pull out chips.

Unibit® or Vari-Bit® Step Drill (1/8" to 1/2") - these bits can be used for sheet up to 0.118" (3 mm) thick to achieve a variety of hole diameters with a single bit. They require maximum support behind the sheet during use to prevent cracking.

Hole Saws w/center pilot drill arbor (3/4" to 6") - these require cooling while cutting to prevent stress build up in the sheet. They leave a poor finish on the inside of the hole. They are useful for rough passage holes for installation of HVAC, plumbing or electrical wiring.

Trouble Shooting

Problem	Cause	Solution
Chipping	Feed rate too fast	Reduce feed rate
	Rake angle of bit too large	Rake angle should be 0 to 4°
	Sheet vibration	Clamp sheet tightly and use solid backing
	Drill bit wobble	Replace bit or chuck
Melting	Feed rate too slow	Increase feed rate
	RPMs too high	Reduce RPMs
	Heavy chip load	Clear chip buildup Increase twist angle of bit
	Insufficient coolant	Increase coolant (water) supply
	Clearance angle too small, (not enough back relief)	Regrind drill bit to 12 to 15° clearance angle
Irregular Hole	Drill bit is not true	Regrind drill bit
	Bent drill bit	Replace bit
	Worn chuck	Replace chuck
	Worn spindle	Replace spindle or spindle bearings

For additional information contact:

Degussa, CYRO Industries

379 Interpace Parkway,
PO Box 677, Parsippany, NJ 07054-0677

800-631-5384
www.cyro.com
www.degussa.com

CYRO Industries is a wholly-owned subsidiary of Degussa.

Additional Technical Information and Assistance

We invite you to visit our TechKnowlogy Center on www.cyro.com.

Visitors have immediate access to frequently asked questions, technical concerns, physical properties, processing conditions, fabrication tips, regulatory compliance information, engineering guidelines, tips for troubleshooting, and hundreds of other facts about acrylics from one of North America's leading manufacturers of acrylic-based polymer and sheet products.



Fire Precautions

ACRYLITE FF sheet is a combustible thermoplastic. Precautions should be taken to protect this material from flames and high heat sources. ACRYLITE FF sheet usually burns rapidly to completion if not extinguished. The products of combustion, if sufficient air is present, are carbon dioxide and water. However, in many fires sufficient air will not be available and toxic carbon monoxide will be formed, as it will when other common combustible materials are burned. We urge good judgement in the use of this versatile material and recommend that building codes be followed carefully to assure it is used properly.

Compatibility

Like other plastic materials, ACRYLITE FF sheet is subject to crazing, cracking or discoloration if brought into contact with incompatible materials. These materials may include cleaners, polishes, adhesives, sealants, gasketing or packaging materials, cutting emulsions, etc. See the Tech Briefs in this series for more information, or contact your ACRYLITE Sheet Distributor or the CYRO Technical Center for information on a specific product.

Important Notice:

The information and statements herein are believed to be reliable but are not to be construed as a warranty or representation for which we assume legal responsibility. Users should undertake sufficient verification and testing to determine the suitability for their own particular purpose of any information or products referred to herein. NO WARRANTY OF FITNESS FOR PARTICULAR PURPOSE IS MADE. Nothing herein is to be taken as permission, inducement or recommendation to practice any patented invention without a license.

