

Edge of Arlington Saw & Tool, Inc.

124 South Collins
Arlington, TX 76010
Phone: 817-461-7171 • Fax: 817-795-6651
Toll Free: 888-461-7171
Email: info@eoasaw.com
Website: www.eoasaw.com



Item #47198, Amana Tool Carbide-Tipped Downcut Overhang Trim 3/16 Overhang x 1/2 Dia x 1 x 1/4 Inch Shank \$28.01

Thank you for shopping with us! Stage flush trimming cuts, whether in laminate work or template work, with these bits. Trimming the material in two passes reduces chipping in laminates and tearout in solid wood. A preliminary cut with the overhang bit leaves a small overhang in laminate or template work, an edge slightly protruding the template. Complete the operation with a final pass, using a standard trim bit.

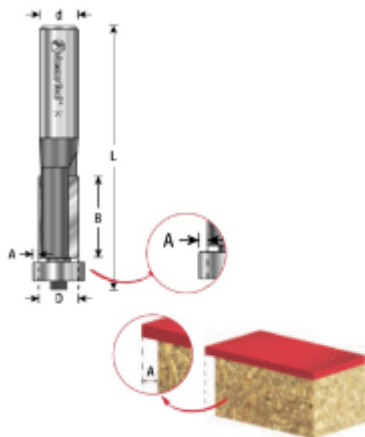

SPECIFICATIONS

Manufacturer	Amana Tool
Diameter	1/2 in
Cut Depth	3/16 in
Cut Height, Length, or Width	1 in
Bearing(s)	47719
Flute Geometry	Downcut
Flute	2
Overall Length	2 5/8 in
Shank	1/4 in