

Edge of Arlington Saw & Tool, Inc.

124 South Collins

Arlington, TX 76010

Phone: 817-461-7171 • Fax: 817-795-6651

Toll Free: 888-461-7171

Email: info@eoasaw.com

Website: www.eoasaw.com



Amana Tool Cut-Out 4-Wing

Edge of Arlington offers free shipping in the United States when you choose flat rate shipping.

Use for cutting out undermount bowls. Surell®, Fountainhead®, and other solid surface undermount bowls. For Corian® bowls, must be used with a Corian® bowl template.

To achieve the best possible results, use these bits with a variable speed router—minimum horse power: 2 1/2 Speed; 12,000 RPM or less.

Warning: Maximum RPM = 12,000

57165: Bearing #'s 47745 & 47747, Spacer #55371, Collar #47739, Key #5002

57166: Bearing #47749, Spacer #55363, Collar #47739, Key #5002

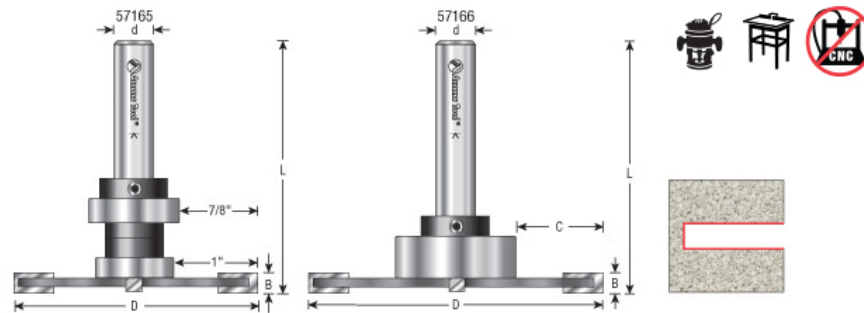

Item #	Diameter	Cut Depth	Cut Height/Length	Flute	Overall Length	Shank	Price
57165	3 in	7/8, 1 in	3/16 in	4	3 5/32 in	1/2 in	\$111.94
57166	3 5/8 in	1 in	1/4 in	N/A	3 9/32 in	1/2 in	\$156.71